

FEATURE a unique proven design

SI 25

TECHNICAL DATA

SI 25

The **SI 25 Regulator** was created in response to the industry's need for a Ultra High Purity **Highflow, Springless, Tied Diaphragm Regulator** for specialty source gas service, i.e. gas cabinets. The design and materials of construction, plus some unique features make it an ideal choice for gas source applications with reactive and hazardous gases the Semiconductor and Allied Industries use.

- Unique features include a special leak test port that enables the diaphragm seal to be outboard leak tested 10^{-9} mbar.l./sec range.
- Precise control of the gas discharge with minimum deviation caused by the supply pressure effect.
- Counter balance springs outside the gas stream to ensure the unit functions correctly with downstream vacuum.
- A unique spherical ball pressure pad to give ultra smooth delivery pressure adjustment.

Individual Serial number, for full traceability

Ergonomic Design

Spherical ball for ultra smooth control

Metal to metal seal to Atmosphere

Sealed bonnet for extra protection

Minimal wetted surfaces for easy purging

Gas specific solutions (Body and Seat Materials)

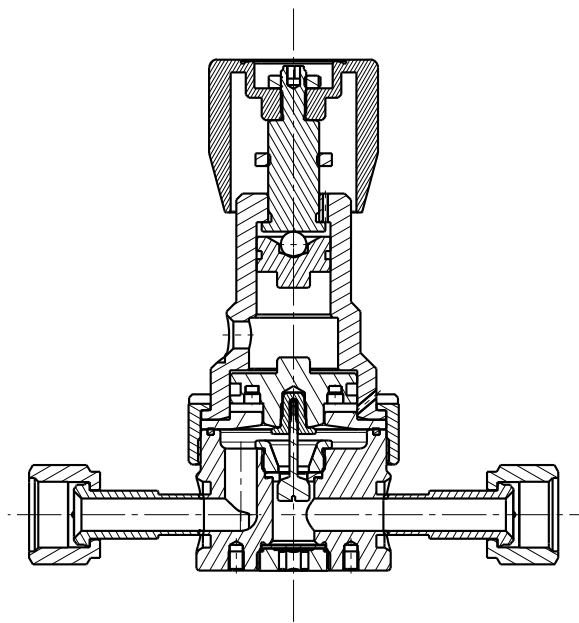

Assembling, testing & Packaging in cleanroom Cl. 10

Controlled (PC) electropolishing for better corrosion resistance

Springless & threadless for zero particle emission

2,3,4,5 or 6 ports options available

diaphragm counter balance springs

Excellent response (droop, hysteresis, creep)

Manufactured to the **THREE STAR PROCESS®**

TECHNICAL DATA	
Fluid Media	Standard, High and Ultra High Purity, corrosive and oxydizing gases (NF3, F2, ...)
Inlet pressure (PVDF seat)	25 bar (365 PSI)
Outlet pressure	8 bar (116 PSI)
Temperature range	-20°C to + 60°C (-2F to 140F)
Nominal Flow	1000 slpm (N ₂)
Flow Coefficient (C _v)	C _v = 1,0
Certified max. Helium inboard leak rate	$1 \cdot 10^{-9}$ mbar.l./sec
Certified max. Helium outboard leak rate (at max. pressure)	$1 \cdot 10^{-9}$ mbar.l./sec
Certified max. Helium across the seat leak rate (at max. pressure)	$1 \cdot 10^{-6}$ mbar.l./sec
Number of ports	2, 3, 4, 5 or 6

CONSTRUCTION MATERIALS

DIMENSIONS

	Parts	Materials
Wetted parts	Body	AISI 316L, VAR, Hastelloy®
	Diaphragm	Hastelloy®
	Seat	PCTFE (Kel-F®), on request: PI (Vespel®) or PVDF
	Poppet	AISI 316L, on request: Hastelloy®
Non-wetted parts	Bonnet	Chrome Plated Brass
	Handle	Aluminium
	Others	Stainless Steel or others

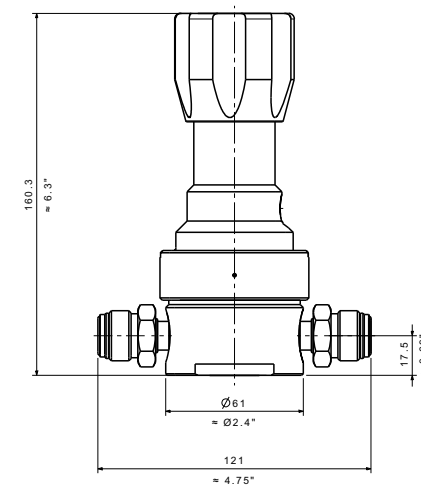
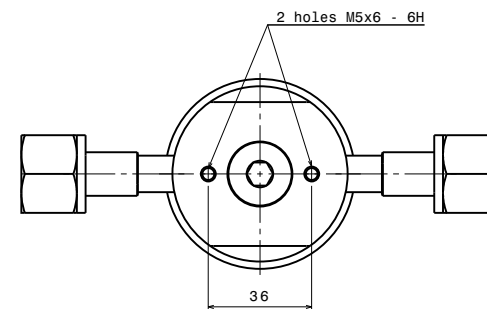

PART NUMBER							
Example :	SI 25 U	2V1	A	/	K	8 b	A/B : V-1/2 F
	1	2	3		4	5	6

1 - Serie & Surface Finish	
SI 25 U	Ra 0,15µm EP. (6µin Ra)
SI 25 V	Ra 0,25µm EP. (10µin Ra)
SI 25 S	Ra 0,4µm nonEP (15µin Ra)

2 - Ports Configurations	
2V1	2 ports in line
See below for other ports configurations	

3 - Body Material (others on request)	
A	AISI 316L, VAR
I	AISI 316L
H	Hastelloy® (on request)

4 - Seat Material	
K	PCTFE (Kel-F®)
P	PVDF (optional)
V	PI (VespeI® optional)

5 - Outlet regulated Pressure	
8b	8 bar - 116 PSI
Note : Inlet Pressure: upto 25 bar (365 PSI)	

6 - End Connections	
V-1/2 F	GAZEL® 1/2" - Female (face seal)
V 1/2 M	GAZEL® 1/2" - Male (face seal)
V-FI	GAZEL® 1/4" - Internal Female (face seal) for gauge connections only

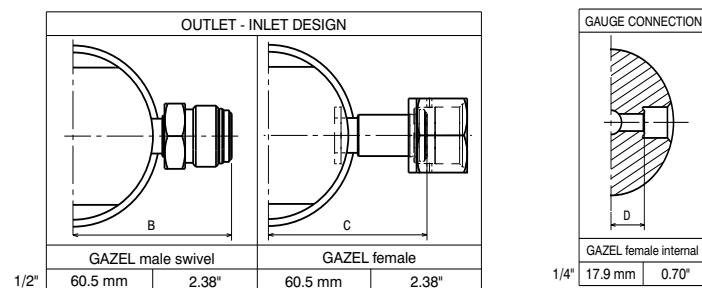

Configurations					
2V1	2V2	2V3	3V3	3V4	4V5
4V6	4V9	5V7	5V8	5V10	5V11
5V12	5V13	6V2			

*All GAZEL® Face Seals are VCR® compatible. VCR® is a registered trade mark of SWAGELOK COMPANY., HASTELLOY® is a registered trade mark of CABOT Corp., Kel-F® is a registered trade mark of 3M company, VespeI® is a registered trade mark of DUPONT



SELFA

Valves & Fittings

A total component solution, from source to process

SI 25
TIED DIAPHRAGM PRESSURE REGULATOR
FOR HP & UHP HIGH FLOW
APPLICATIONS



25

