

Need advice?  
Click here to contact us!

TEESING

WWW.TEESING.COM

► *mott corporation*  
Process Systems

Safe, reliable,  
fully automated  
catalyst recovery.  
The Mott solution.



WWW.TEESING.COM | TEL +31 70 413 07 50

# Maximizing catalyst retention.

## Introduction.

Process operations involving catalysts have traditionally used leaf filters for catalyst recovery, and either bag filters or plate and frame filters for catalyst removal. Modern filter technology, utilizing sintered porous metal tubes, provides superior filtration in both applications, and porous metal is now being specified in new construction and in the retrofit of existing systems. In addition to offering superior filtration, these porous metal filters reduce operator exposure to process materials, and reduce or eliminate disposal costs for spent filtration media.

Mott Corporation's HyPulse® LS Series filters have been applied extensively throughout the chemical and hydrocarbon processing industries for removal and recovery of supported precious metals and other valuable catalysts. Mott offers four HyPulse configurations, each designed for specific catalyst removal and recovery applications.

- **HyPulse LSI:** Employs inside to outside flow path, proven effective in high solids batch or continuous operations where maximum filtrate recovery is required.
- **HyPulse LSM:** Specifically applied to catalyst recovery processes with high specific gravity solids (such as RANEY® nickel). This highly versatile design can also be configured for close-coupled CSTR interface in a cross-flow mode to maximize continuous product recovery during extended campaigns.
- **HyPulse LSP:** Our conventional outside to inside configuration, ideally suited for low-solids polishing applications.
- **HyPulse LSX:** Conventional crossflow microfiltration applied when fine or attrited catalysts are present.



## Advantages of HyPulse® LSI filters in catalyst filtration.

Mott Corporation recommends the HyPulse LSI Filter configuration for most catalyst applications. The following is a brief description of distinct LSI benefits.

### Superior Filtrate Quality.

- Exceptional filtrate quality, with less than 1 ppm particulate. Mott porous metal filter elements are specifically engineered for complete particle removal.
- Superior filtrate quality is achieved without the use of a precoat or a polishing filter.

### Filtrate and Catalyst Recovery.

- 95-100% of the filtrate is recovered in each cycle. The amount of heel has been minimized in the unique LSI design.
- 100% of the catalyst is recovered from the filter and can be returned to the reactor after each cycle. This is especially important when an expensive catalyst is used and when efficient catalyst recycle is required.

### Closed System.

- The filtration system is sealed from operator exposure. The filter's clean operation and handling ease make it ideal for applications utilizing pyrophoric catalysts, dangerous chemicals, and/or solvents.
- Mott HyPulse Filters can be put in line with the process stream. No feed tank is required for many applications.

### Utilities.

- A minimal amount of downtime and maintenance is required for operation. "Permanent" porous metal filter elements eliminate the need for frequent cartridge or bag replacement and disposal.
- Filters have no moving parts.
- Filters can be fully automated.

### Inside-Out Filtration.

- The HyPulse LSI eliminates traditional cake bridging and channel flow problems.
- A smaller filter housing is required because elements are packed closer together.

### Solids Discharge.

- Solids can be removed from the filter as a low-solids slurry backwash or as a high-solids wet cake.

### Wide Range of Materials.

- Rigid Mott porous metal filter elements are available in a wide variety of materials. Standard elements are made of 316LSS. Optional materials include 304LSS, Inconel®, Monel®, Hastelloy®, Alloy 20, and titanium.

### Long Product Life.

- Long element life is ensured by correctly matching the type of porous media with a given catalyst and process liquid.

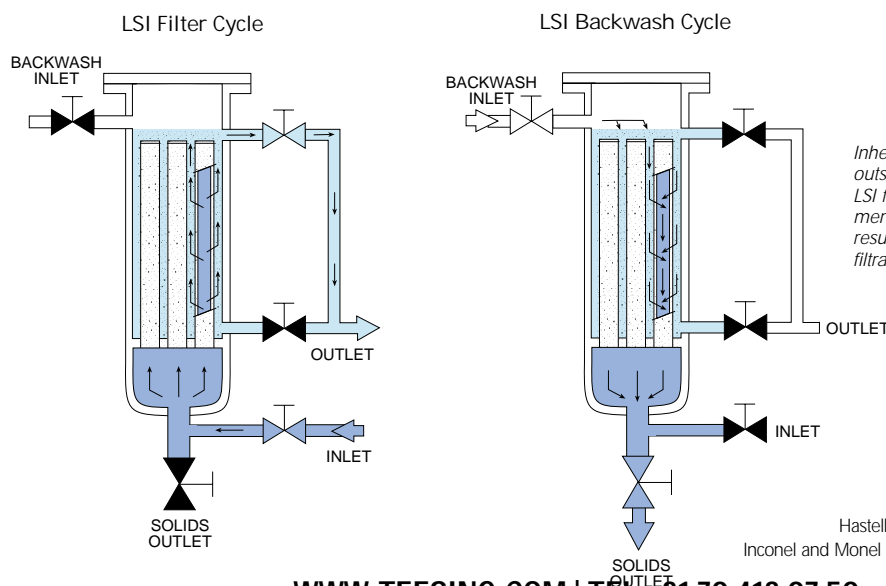

Hastelloy is a registered trademark of Haynes International, Inc.  
Inconel and Monel are registered trademarks of Special Metals Corporation.



### Mott HyPulse LSI catalyst filtration process.

A simplified installation schematic for the HyPulse LSI in a typical catalyst application is shown below.

A general description of a typical operation is as follows:

#### Slurry Backwash Recycle – Primary Catalyst Filter.

1. Valve (1) is opened. The reactor is pressurized to move the feed slurry.
2. Valve (2) is opened. Solids collect on the inside of the porous elements while filtrate moves through an open valve (3) and is collected downstream.
3. The filtration continues at a constant flow rate until the batch from the reactor is completely filtered.
4. Valves (2) and (3) close. Backwash gas valve opens and housing is pressurized.
5. Catalyst solids are discharged through valve (4) directly into the reactor using liquid and a pressurized gas pulse.
6. When the next reaction is completed, Step 1 is again initiated.
7. This recycling system continues until the catalyst has lost activity and requires regeneration.

### Removal of catalyst from the reactor system.

Many reactor systems require that a portion of the catalyst be replaced for each cycle. This illustration shows a typical HyPulse LSI catalyst filtration application.

#### Wet Cake Discharge – Solids Purge Filter.

1. Filtration is the same as for the primary catalyst filter except that the feed slurry is periodically directed through valves (1), (5), and (6) to the solids purge filter.
2. When the filtration is completed, the shell is drained and the cake is partially dried with gas pressure. Subsequently, the heel is drained from the filter.
3. To discharge the wet cake, the filter is pressurized with blowdown gas and valve (7) is opened. The solids are discharged into a drum (which can be sent for regeneration).
4. Catalyst is replaced from the catalyst make-up tank.

### Mott HyPulse LSI Catalyst Filtration Process

Slurry backwash flow diagram

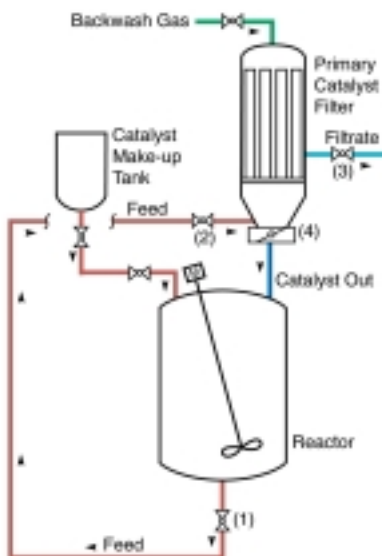

Slurry backwash with spent catalyst recovery

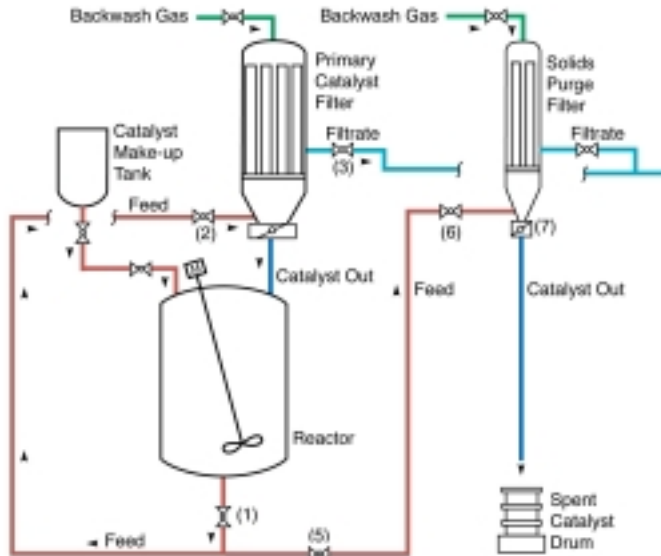

## HyPulse LSM filters design versatility.

Mott's unique HyPulse LSM design incorporates all of the features available in the LSI design, with the added capability of introducing feed to the top of the filter. This feature eliminates the potential for classification of high-density solids which can occur in an upflow mode. As shown below, the patented LSM design utilizes "double open-ended" filter elements which allows for incorporation as crossflow filters into recirculating reactor loop systems.

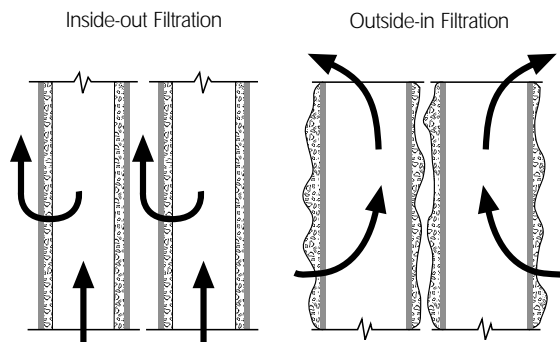

Inside-out filtration used in Mott HyPulse LSI and LSM filters results in more uniform deposition, and more secure retention of solids, while eliminating the problem of cake bridging between elements often associated with outside-in filtration.

LSM Process Filter

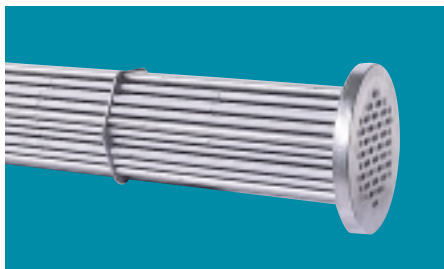
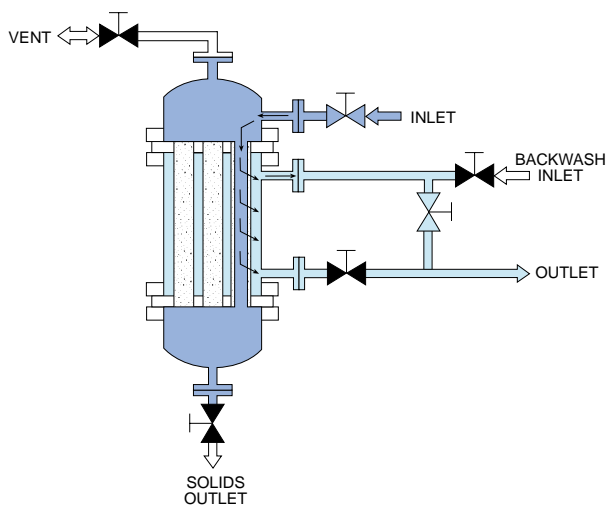

Close-packed filter elements enable Mott to design compact LSI and LSM systems with more total filtration area than much larger competitive systems.

LSM filter option flowsheet

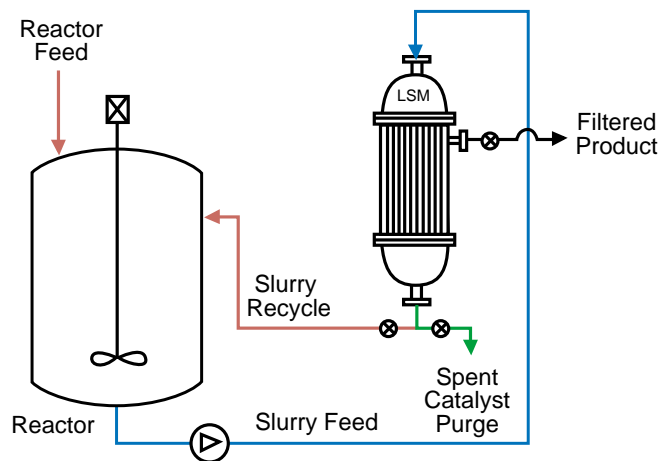

HyPulse LSI and LSM filters are used in catalyst removal and recovery applications in multiple industries ranging from food and ingredient manufacturers to petroleum refineries. Two recent applications are described below.

### LSI application.

A U.S. manufacturer of proprietary food additives needed to recover palladium on carbon following each hydrogenation batch. It was important to design the filter based on solids-holding capacity in order to process a complete batch prior to backwashing. The HyPulse LSI provided this customer with high product recovery in the filtrate and concentrated catalyst for recycle.

#### PROCESS INFORMATION

Liquid Product	n-Propanol Carrier for Food Additive
Solids Separated	Palladium on Carbon Catalyst, 0.5 wt%
Batch Size	800 Gallons
Temperature	190°F
Pressure	15 PSIG

#### EQUIPMENT

HyPulse LSI	Model No. 841660 (Jacketed)
Housing	16" Diameter
Elements	(19) 2.5" Diameter, 60" Long, Grade 0.5
Surface Area	60 ft <sup>2</sup>

### LSM application.

A U.S. Gulf Coast chemical manufacturer of organic compounds required the removal of RANEY nickel from a recirculation loop coupled to a hydrogenation reactor. The LSM filtration system provided for this service delivers 200 gpm of filtered product with minimal downtime for backwashing.

#### PROCESS INFORMATION

Liquid Product	Crude Butanol
Solids Separated	RANEY Nickel Catalyst, 1.0 wt%
Flow Rate	200 GPM
Temperature	300°F
Pressure	400 PSIG

#### EQUIPMENT

HyPulse LSM	Model No. 883680 (Skid Mounted)
Housing	36" Diameter
Elements	(127) 2" Diameter, 80" Long, Grade 0.5
Surface Area	415 ft <sup>2</sup>

## HyPulse LSP filters.

Mott can apply its conventional outside-inside flow configuration (HyPulse LSP) in cases where only trace quantities of solids are present (typically < 100 ppm). In these “polishing” applications, there is little concern for significant development of filter cake on the outer diameter of the elements, and element spacing is not as critical as is the case for most catalyst recovery operations.

Applied to polishing applications, the HyPulse LSP is designed with an economic, close-packed, removable filter element bundle. Backwash liquids from the LSP filter are usually pumped as low-solids slurries.

## HyPulse LSX filters.

Some catalyst systems do not lend themselves to formation of permeable cake with good release characteristics upon backwashing. Mott may recommend HyPulse LSX crossflow filters in such cases. During operation of the LSX, feed is pumped through the inner diameter of the LSX filter elements at velocities up to 20 ft/s. The turbulence developed at these velocities helps to continually remove particulate from the filter surface. Backpulsing or clean in-place procedures can be applied as needed.

Removal and recovery of heterogeneous catalysts represents the flagship application for Mott’s HyPulse LS Series filters. With numerous Fortune 500 repeat customers, Mott remains the preferred choice for state-of-the-art catalyst management and associated product yield.

## Laboratory and design capabilities.

### Microscopic evaluation in the lab – macroscopic evaluation in the field.

For thorough evaluation of new applications, Mott maintains a Development and Testing Laboratory. Both scanning electron and optical microscopes, along with computer-controlled porometers, are used to inspect pore size, shape, and distribution. Particle counters, particle-size analyzers and a fully instrumented test stand are used to evaluate filter performance.

- Feedstock profiling
- Filtration feasibility
- Solids characterization
- Material compatibility and selection

Often our laboratory evaluations provide a suitable basis for filter designs. If additional evaluations are recommended, Mott offers portable HyPulse filter systems that are fitted with the filter elements to be tested, and configured for the customer’s application. After the system is transported to the testing site and installed, Mott engineers assist with start-up and data acquisition followed by scale-up.

