

Type **TSA6 CNG**

Inline breakaway Coupling

for bus and truck fuelling stations



General

DESCRIPTION

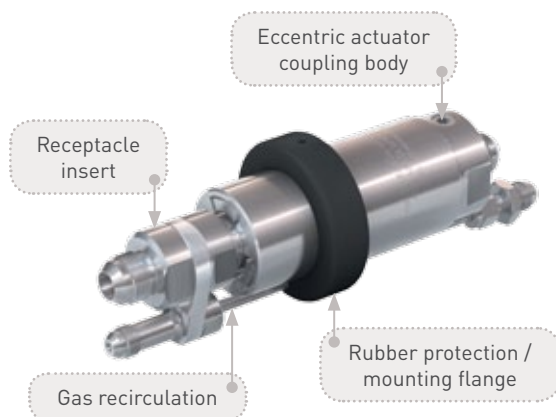

Features

- Re-usable without factory reservicing
- Installation inbetween the filling and venting hoses
- Small compact design
- Rubber protection / mounting flange
- Eccentric actuation via an allen wrench
- Option: without gas recirculation

With type TSA6 CNG, an inline breakaway coupling which is installed inbetween the filling and venting hoses, is now also available for bus and truck fuelling stations. In the event of accidental deployment, e.g. driving a vehicle from the dispenser with the nozzle remaining in the vehicle fuel port, the coupling will separate the connections between dispenser and hoses sealing both ends. This protects largely the receptacle, the fuelling nozzle and the dispenser against damage. The detached coupling can be easily reattached and placed back in service after having been function tested.

The breakaway device consists of a coupling body, a receptacle insert and an optional gas recirculation.

We recommend the installation of a type TSF5 CNG filter (see page 104, catalogue no. 15) when using the TSA6 CNG inline breakaway coupling.

The filter protects your system from dirt ingress.

We also offer complete hose assemblies consisting of a fuelling nozzle, a hose set and a breakaway coupling (for complete hose assemblies see respective fuelling nozzle).

Application

Inline breakaway coupling for bus and truck fuelling stations for installation inbetween the filling and venting hoses.

TECHNICAL DATA

Characteristic	Basic version	Options
Nominal bore DN	12 mm	On request
Pressure range	PN = 200 bar (3,000 psi) PS = 300 bar PT = 450 bar PN = 250 bar (3,600 psi) PS = 350 bar PT = 525 bar	
Temperature range	-40 °C up to +85 °C (-40 °F up to +185 °F)	On request
Breakaway force	300 - 600 N	On request
Material	Corrosion resistant stainless steel, aluminium	On request
Sealing material	Natural gas compatible	On request
Design	With gas recirculation	Without gas recirculation
Registration	PED97/23/EC: CE0036	

Ordering

ORDERING | Inline breakaway coupling TSA6 CNG with gas recirculation

approx. dimensions (mm)

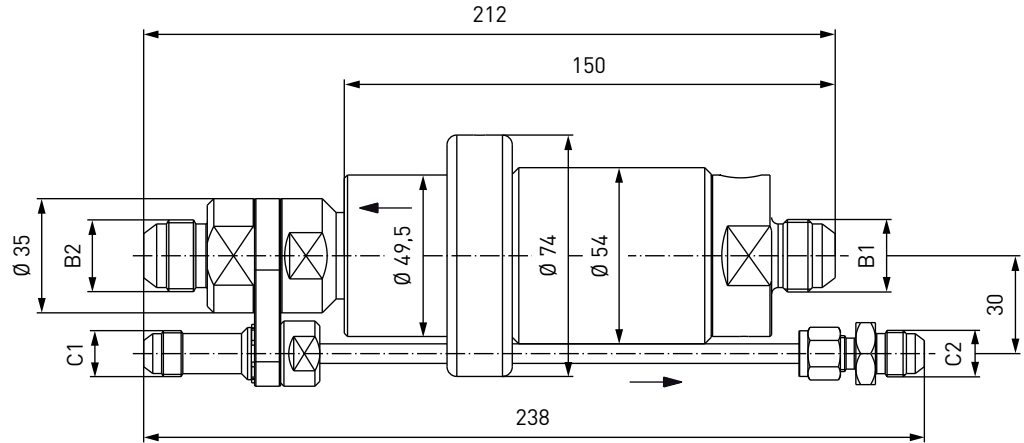

Part No.	Description	Pressure (PN)	B1/B2 (external thread)	C1/C2 (external thread)
C1-78834	TSA6 CNG	200 bar / 3,000 psi	UNF 7/8"-14*	UNF 9/16"-18*
C1-102493	TSA6 CNG	250 bar / 3,600 psi	UNF 7/8"-14*	UNF 9/16"-18*
C1-71057	TSA6 CNG	200 bar / 3,000 psi	UNF 7/8"-14*	UNF 7/16"-20*

* acc. to SAE J514, 37°

ORDERING | Inline breakaway coupling TSA6 CNG without gas recirculation

approx. dimensions (mm)

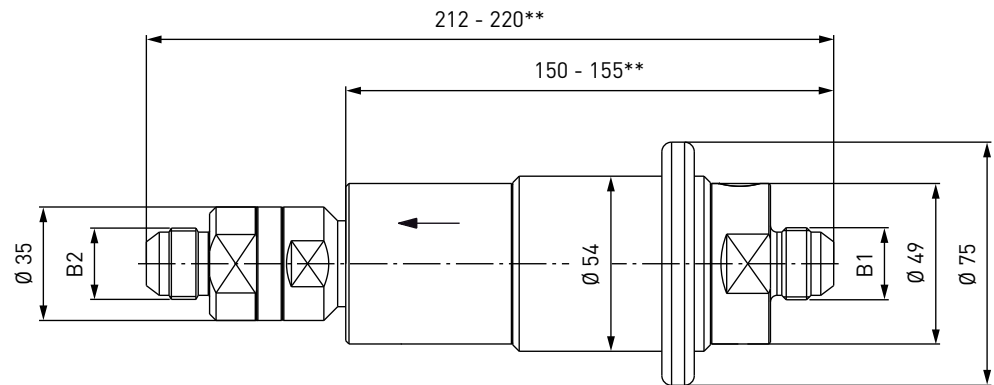

Part No.	Description	Pressure (PN)	B1/B2 (external thread)
C1-76955	TSA6 CNG	200 bar / 3,000 psi	UNF 7/8"-14*
C1-102492	TSA6 CNG	250 bar / 3,600 psi	UNF 7/8"-14*
C1-74444	TSA6 CNG	200 bar / 3,000 psi	UN 1 1/16"-12*

* acc. to SAE J514, 37°

** length depending on type of breakaway coupling

Accessories

ACCESSORIES

The following accessories are available for type TSA6 CNG:

Filter TSF5 CNG (50 micron)

For upgrading existing inline breakaways without integrated filter, we recommend the installation of a type TSF5 CNG filter (see page 104, catalogue no. 15). The filter protects your system from dirt ingress. Type TSF5 CNG is installed as prefilter in the media inlet between inline breakaway coupling and filling hose.



Part No.	Description	DN	Pressure (PN)	Inlet B	Outlet A
C1-105923	TSF5 CNG (CE)	12	200 bar / 3,000 psi	UNF 7/8" -14* external thread	UNF 7/8" -14* internal thread

* acc. to SAE J514, 37°

Filling and venting hoses

Please see page 122 in catalogue no. 15 or the corresponding fuelling nozzles for filling and venting hoses suitable for the type TSA6 CNG inline breakaway coupling.

Fittings

Stainless steel fittings for connecting the media inlet 'B' to the filling hose or the gas recirculation inlet 'C' to the venting hose.

Part No.	Description	Connection breakaway	Connection filling hose
C1-97227	Fitting	UNF 9/16" -18* internal thread	UNF 9/16" -18* internal thread
C1-79538	Fitting	UNF 9/16" -18* internal thread	UNF 9/16" -18 ** internal thread
E80-647P	Fitting	UNF 9/16" -18* internal thread	UNF 7/8" -14* external thread
C1-66850	Fitting	UNF 9/16" -18* internal thread	UNF 3/4" -16* external thread
C1-65592	Fitting	UNF 9/16" -18* internal thread	NPT 1/4" internal thread
E80-52705	Fitting	UNF 7/8" -14* internal thread	UNF 9/16" -18* external thread
C1-105411	Fitting	UNF 7/8" -14* internal thread	UNF 7/16" -20* external thread
C1-48976	Fitting	UNF 7/8" -14* internal thread	NPT 1/4" external thread

* acc. to SAE J514, 37°

** acc. to SAE J1926

Please see page 126 in catalogue no. 15 onwards for a detailed overview on all available fittings.

Accessories

Spare parts

Various parts are available as spares for type TSA6 CNG:

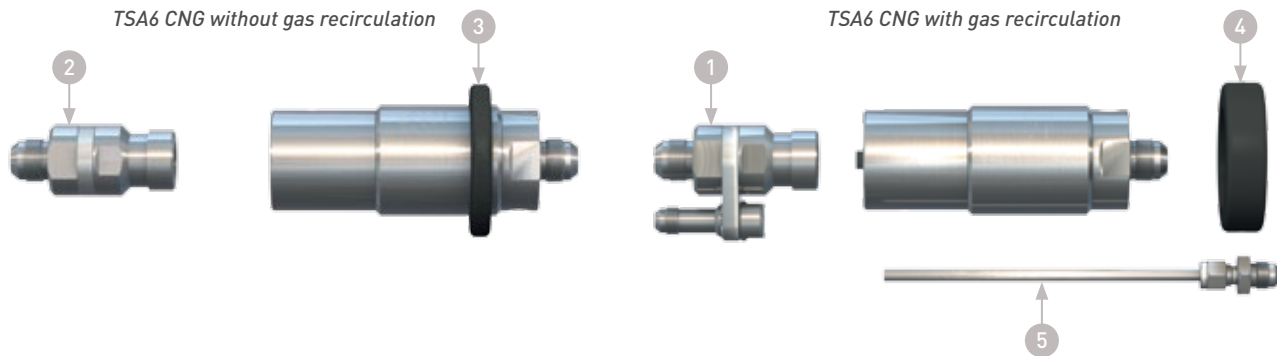

Part No.	Description
W83706	1 Receptacle insert for type TSA6 CNG with gas recirculation (C1-78834, C1-102493)
W71060	1 Receptacle insert for type TSA6 CNG with gas recirculation (C1-71057)
W106557	2 Receptacle insert for type TSA6 CNG without gas recirculation (C1-76955, C1-102492)
W74634	2 Receptacle insert for type TSA6 CNG without gas recirculation (C1-74444)
E80-76830	3 Rubber protection
E80-72682	4 Mounting flange
E80-71101	5 Gas recirculation tube
C1-119726	Spare seal set for receptacle insert W83706 and W71060
C1-119725	Spare seal set for receptacle insert W106557 and W74634

Other products

OTHER PRODUCTS

You will find more products in our current catalogue no. 15



Further information on our homepage
www.weh.com

© All rights reserved, WEH GmbH 2013. Any unauthorized use is strictly forbidden. Subject to alteration. No liability will be assumed for any content. Herewith previous versions are no longer valid.

» Contacting

For queries and further information, please do not hesitate to contact us.

Manufacturer:

WEH GmbH Gas Technology

Josef-Henle-Str. 1
89257 Illertissen / Germany

Phone: +49 7303 95190-0

Fax: +49 7303 95190-9999

eMail: ngvsales@weh.com

www.weh.com